

EP800 电—气定位器 Electro-Pneumatic Positioner

概 要

EP800 系列电—气定位器与气动执行机构配套使用，输入 4~20 mA DC 的信号转换成输出空气压力，控制执行机构的动作。同时根据执行机构的行程进行反馈，从而使执行机构的行程能按控制信号进行精确定位。

EP800 系列电—气定位器能用于单动作型和双动作型执行机构。

GENERAL

The EP800 Series Positioner, mounted on a pneumatic actuator, moves the actuator by receiving DC 4~20 mA signals from a controller. Also, the function of detecting and returning the actuator displacement provides accurate positioning in response to DC 4~20 mA signals.

The EP800 can be used with both spring-return and double acting actuators.

标准规格 STANDARD SPECIFICATIONS

系 列 Series	EP800
输 入 信 号 Input signal	4~20 mA DC 可进行分程控制 调整范围: 4~12、12~20 mA DC
输 入 阻 抗 Input impedance	250 Ω ±5% at 25°C
输 出 特 性 Characteristic	线性 Linear
放 大 器 Pilot valve	单动作型执行机构和双动作型执行机构兼用, Non-bleeding type. 单动作正作用型放大器易变换成反作用型放大器(输入信号增加, 输出气压相应减小)。 available.
气 源 压 力 Air supply	140~700 KPa
耗 气 量 Air consumption	输出气压 50%时的耗气量。 Output air pressure 50% 单动作型 Single acting type : 5NI / min at 140 Kpa air supply 双动作型 Double acting type : 15NI / min at 400 Kpa air supply
最大处理容量 Max. capacity	输出侧气源放空时 Capacity when output is atmospheric venting. 单动作型 Single acting type : 175NI / min at 140 Kpa air supply 双动作型 Double acting type : 400NI / min at 400 Kpa air supply
性 能 Performance	单动作型执行机构 For single acting actuator 直 线 性 Linearity.....±1.0% of Full stroke 滞 后 Hysteresis..... 0.5% of Full stroke 灵 敏 度 Response level..... 0.1% of Full stroke 重 复 精 度 Repeatability..... 0.2% of Full stroke 气源压力变动误差 Supply pressure effect..... 0.1%/10 Kpa 双动作型执行机构 For double acting actuator 直 线 性 Linearity.....±1.5% of Full stroke 滞 后 Hysteresis..... 0.8% of Full stroke 灵 敏 度 Response level..... 0.2% of Full stroke 重 复 精 度 Repeatability..... 0.3% of Full stroke 气源压力变动误差 Supply pressure effect..... 0.4%/50 Kpa 上述各数值是指在不连接阀门的情况下执行机构的性能。在连接阀门的情况下, 其性能请参照相应的 KOSO 控制阀标准说明书。 The above represents the performance of the positioner on an actuator without a valve.For the performance of the complete unit with a valve and an actuator, see KOSO STANDARD SPECIFICATION.
气 源 接 口 Air connection	Rc 1/4
电 气 接 口 Wiring connection	G 1/2
环 境 温 度 Ambient temperature	标准型 Standard type.....-20~+80°C 高温型(选购) High temperature service (option).....0~+100°C 低温型(选购) Low temperature service (option)..... -50~+60°C

湿度范围 Ambient humidity range	10~90% RH
结构形式 Enclosure	室外防水型 Weather proof type (IP65) 耐压防爆型 Explosion proof type (Ex md II CT6) 防爆合格证号: 国仪检 01171 本质安全型 Intrinsically safe explosion proof type (Exia II CT6) 合格证号: 国仪检 01172
附属机构 Standard ancillary	自动—手动切换装置 Auto-Manual change
外壳材料 Housing material	铝合金 Aluminum alloy
表面涂层 Coating	环氧树脂 Epoxy resin group paint
标准涂层色 Coating colors	本体 Body 墨绿 Dark green 外壳 Cover 浅灰 Light gray
重量 Approx. weight	请参照第4~14页。 See page 4~14.
附加规格 Optional specifications	根据客户要求制作。 Available upon request.
电气接口 Wiring connection	1/2 NPT (室外防水型 For weather proof only) 耐压填料式 Packing cable gland (耐压防爆型 For explosion proof only) 密封接头式 Sealing fitting (耐压防爆型 For explosion proof only)
安全栅 Safety device	齐纳安全栅 Zener barrier (Exia II C)
输入信号 Input signal	10~50 mA DC (100 Ω)
压力表刻度 Pressure gauge	Kpa G、Bar、Psi
输出特性 Cam characteristic	等百分比 Equal percentage
气源接口 Air connection	1/4 NPT

CODE NO. EP

型号 Type	A								单动作型执行机构用 For spring return type
	C								双动作型执行机构用 For double acting type
	B								小型单动作执行机构专用 For 5200LA actuator
系列 Series	8								
结构 Enclosure	0								室外防水型 Weather proof type
	1								耐压防爆型 Explosion proof type
	2								本质安全型 Intrinsically safe explosion proof type
反馈方式 Feedback style	1								直行程执行机构用: 标准型 Linear : Feedback for standard lever
	2								角行程执行机构用: 标准型 Rotary : Feedback for lever
	4								角行程执行机构用: 与轴直连连接用 Rotary : For 6300RB, 6500RA, 7300RA
	5								直行程执行机构用: 长行程反馈 Linear : Feedback for long lever
	8								直行程执行机构用: 齿轮、齿条反馈 Linear : Feedback for Rack and gear
输出特性 Cam characteristics	L								线性 Linear
	E								等百分比 Equal percentage
压力表最大刻度 Maximum pressure gauge range	2								200 Kpa (2Kgf/cm ²)
	4								400 Kpa (4Kgf/cm ²)
	10								1000 Kpa (10Kgf/cm ²)
使用环境温度 Ambient temperature limits	—								标准型 Standard type : -20~+80℃ *①
	H								高温型(选购) High temperature service (option) : 0~+100℃
	L								低温型(选购) Low temperature service (option) : -50~+60℃ *①

*① 耐压防爆型的使用环境温度范围为-20~+60℃, 本质安全型的使用环境温度范围为-40~+60℃。

In the case of explosion proof type, explosion proof warranty temperature is -20~+60℃.

In the case of intrinsically safe explosion proof type, intrinsically safe explosion proof warranty temperature is -40~+60℃.

特点

适用于小容量及大容量的执行机构

由于采用了载荷控制弹簧，选择相应的弹簧后就能获得最适合于该执行机构的定位器。

耗气量小

放大器的耗气量小、容量大。

可以选择输出特性

由于反馈机械中有凸轮装置，因此可以选择标准特性以外的输出特性。

各种反馈方式对应的型号

只要更换凸轮装置，就可以用于以下对应的执行机构。

* 直行程执行机构：标准型 EP□8□1

* 角行程执行机构：标准型 EP□8□2

* 角行程执行机构：与轴直连接用 EP□8□4

易转换成反作用放大器

单作用执行机构在需要反作用控制时，正作用型放大器很容易转换成反作用型放大器。

耐压防爆型可在现场进行调整

由于信号(4~20 mA. DC)输入端接头及线圈部位的封装呈耐压防爆结构，因此在进行检修及行程调整时，可以在现场防爆区域内拆除定位器外壳。

本质安全的构造有着广阔的适用范围

接线盒及线圈有着本质安全的构造（力矩线圈型号：EP82），因此与专用的齐纳安全栅组合使用能使力矩线圈适用于所有危险气体的场所（包括0区），使用环境温度范围为-40~+60℃。

FEATURES

USABLE WITH LOW TO HIGH CAPACITY ACTUATORS

By adjusting the built-in capacity control spring, the positioner can be made optimum to the given actuator.

A LOW AIR CONSUMPTION

The pilot valve is low in air consumption and high in capacity.

OUTPUT CHARACTERISTICS SELECTABLE

Having a cam within the feedback construction, choices other than the standard linear characteristic are available.

COMPATIBLE WITH VARIOUS FEEDBACK TYPES

Applicable to the following types by simply exchanging the cam block.

* For Linear type actuator : Feedback for Standard lever type EP□8□1

* For Rotary type actuator : Feedback for lever type EP□8□2

* For Rotary type actuator : Feedback for direct connection to driving shaft EP□8□4

REVERSE ACTION PILOT VALVE EASILY AVAILABLE

The positioner for double acting actuators can be used as a reverse action pilot valve when combined with a spring return actuator that requires a reverse action pilot.

ANTI-PRESSURE AND EXPLOSION PROOF STRUCTURE MARKING ON-SITE ADJUSTMENT POSSIBLE

The anti-pressure and explosion proof construction, with the terminal and coil blocks enclosed together in one package, makes it possible to remove the positioner cover for inside inspection or span adjustment even in an explosive ambient.

INTRINSICALLY SAFE CONSTRUCTION FOR A WIDE SCOPE OF APPLICATIONS

The intrinsically safe construction (torque-coil type: EP82) cover terminals and coil as one package. This, combined with The adoption of the specified zener barrier, makes the unit applicable in all hazardous gas location (including Class 0 area) ranging from low (-40℃) to high (+60℃) temperature environment.

ELECTRO-PNEUMATIC POSITIONER

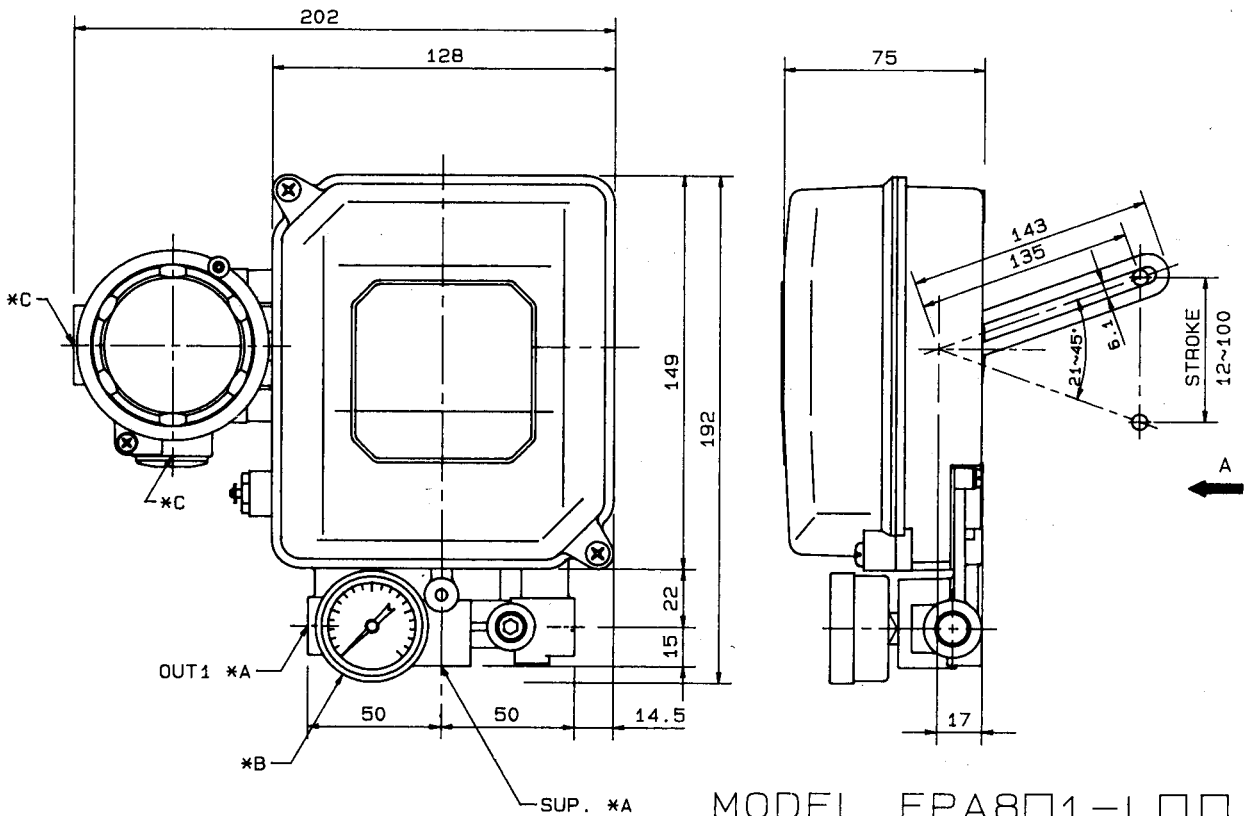

MODEL EPA8□1-L□□

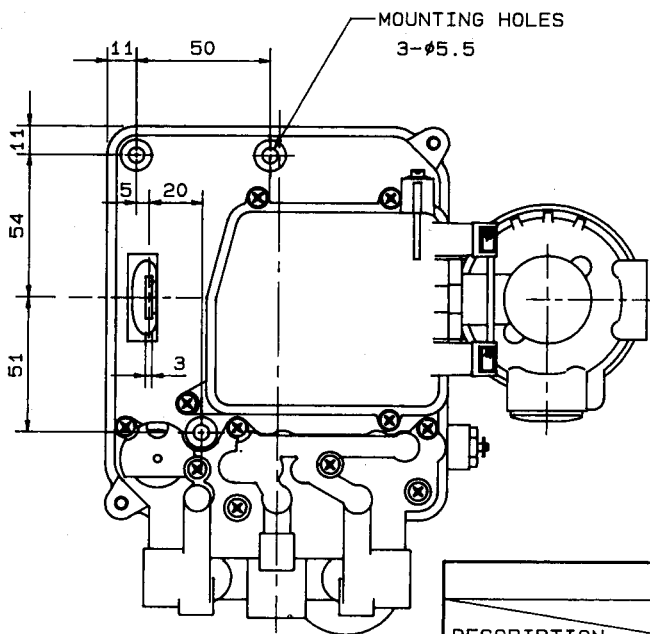

*1	PROOF TYPE	*1	*2	*3
<input type="checkbox"/>	0 WEATHER PROOF			
<input type="checkbox"/>	1 Exmd ICT6			
<input checked="" type="checkbox"/>	2 Exia ICT6			

*2	GAUGE TYPE			
<input type="checkbox"/>	2 2kgf/cm^2	<input type="checkbox"/> 200kPa	<input type="checkbox"/> 2bar	<input type="checkbox"/> 30psi
<input checked="" type="checkbox"/>	4 4kgf/cm^2	<input type="checkbox"/> 400kPa	<input type="checkbox"/> 4bar	<input type="checkbox"/> 60psi
<input type="checkbox"/>	10 10kgf/cm^2	<input type="checkbox"/> 1000kPa	<input type="checkbox"/> 10bar	<input type="checkbox"/> 160psi

*3	SERVICE		
<input type="checkbox"/>	WEATHER PROOF	<input type="checkbox"/> Exmd ICT6	<input type="checkbox"/> Exia ICT6
<input checked="" type="checkbox"/>	-20~80°C <STANDARD>	-20~60°C	-20~60°C
<input type="checkbox"/>	L -50~60°C <LOW TEMP.>		-40~60°C
<input type="checkbox"/>	H 0~100°C <HIGH TEMP.>		

		*A *B CONNECTION		
DESCRIPTION	UNIT	<input type="checkbox"/> kgf/cm^2 kPa	<input type="checkbox"/> bar. psi kPa	<input type="checkbox"/> SPECIAL
*A AIR CONNECTION		Rc 1/4"	1/4"NPT	
*B GAUGE CONNECTION		Rc 1/8"	1/8"NPT	

Rc=PT
G=PF

*C	CONDUIT CONNECTION
<input type="checkbox"/>	G 1/2"
<input type="checkbox"/>	1/2"NPT

APPROX. WEIGHT: 2.3kg

A VIEW

NOTE:

FOR SPRING RETURN ACTING ACTUATOR

DRAWING No.

E-EPA801

REV

E

KOSO

ELECTRO-PNEUMATIC POSITIONER

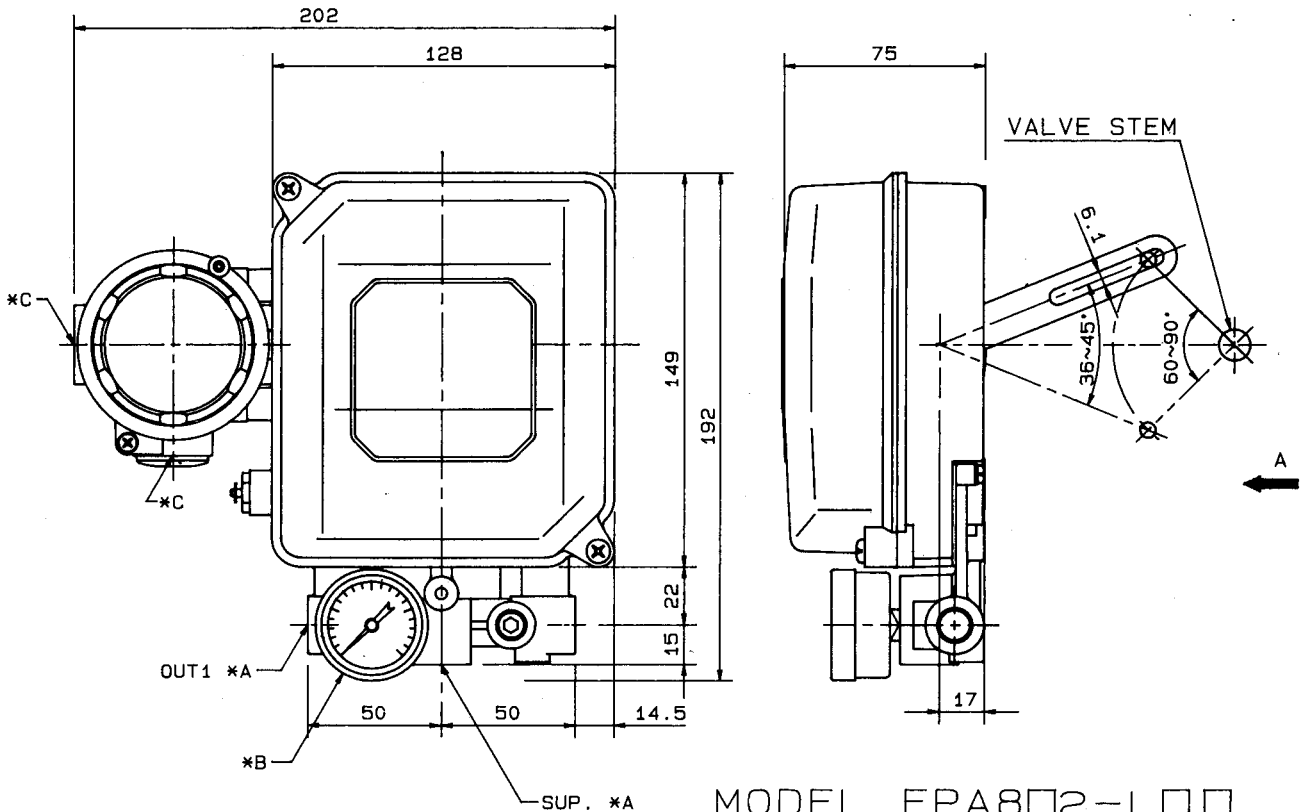

MODEL EPA8□2-L□□

*1	PROOF TYPE	*1	*2	*3
<input type="checkbox"/> 0	WEATHER PROOF			
<input type="checkbox"/> 1	ExmdIICT6			
<input type="checkbox"/> 2	ExiaIICT6			

*2	GAUGE TYPE			
<input type="checkbox"/> 2	<input type="checkbox"/> 2kgf/cm ²	<input type="checkbox"/> 200kPa	<input type="checkbox"/> 2bar	<input type="checkbox"/> 30psi
<input type="checkbox"/> 4	<input type="checkbox"/> 4kgf/cm ²	<input type="checkbox"/> 400kPa	<input type="checkbox"/> 4bar	<input type="checkbox"/> 60psi
<input type="checkbox"/> 10	<input type="checkbox"/> 10kgf/cm ²	<input type="checkbox"/> 1000kPa	<input type="checkbox"/> 10bar	<input type="checkbox"/> 160psi

*3	SERVICE		
<input type="checkbox"/>	<input type="checkbox"/> WEATHER PROOF	<input type="checkbox"/> ExmdIICT6	<input type="checkbox"/> ExiaIICT6
<input type="checkbox"/>	-20~80°C <STANDARD>	-20~60°C	-20~60°C
<input type="checkbox"/> L	-50~60°C <LOW TEMP.>		-40~60°C
<input type="checkbox"/> H	0~100°C <HIGH TEMP.>		

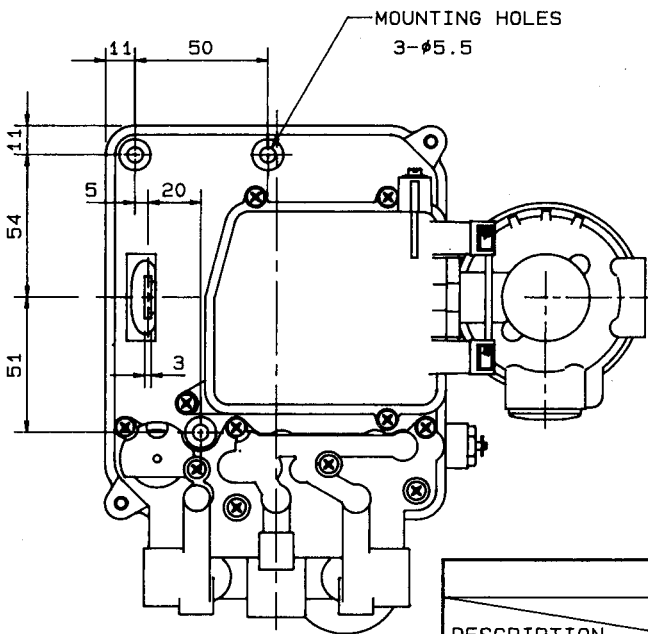

		*A *B CONNECTION		
DESCRIPTION	UNIT	<input type="checkbox"/> kgf/cm ² kPa	<input type="checkbox"/> bar, psi kPa	<input type="checkbox"/> SPECIAL
*A	AIR CONNECTION	Rc 1/4"	1/4"NPT	
*B	GAUGE CONNECTION	Rc 1/8"	1/8"NPT	

Rc=PT
G=PF

*C	CONDUIT CONNECTION
<input type="checkbox"/>	G 1/2"
<input type="checkbox"/>	1/2"NPT

APPROX. WEIGHT: 2.3kg

A VIEW

NOTE:

FOR SPRING RETURN ACTING ACTUATOR

DRAWING No.

E-EPA802

REV

E

KOSO

ELECTRO-PNEUMATIC POSITIONER

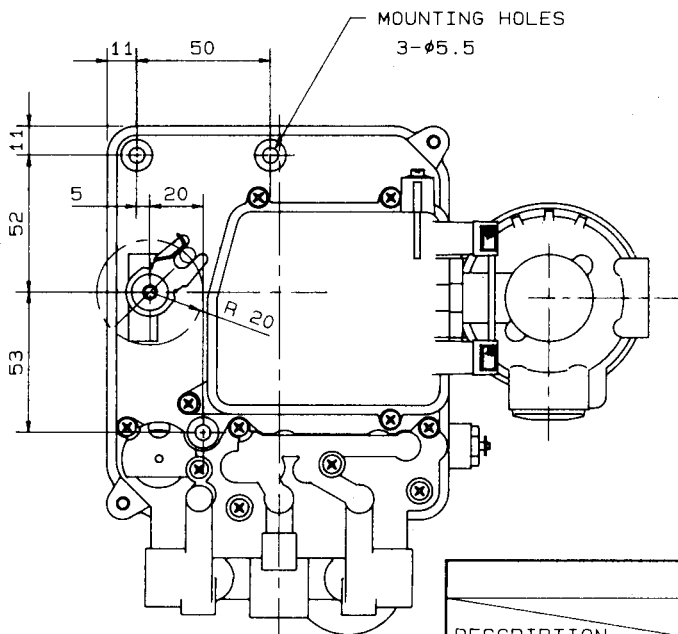
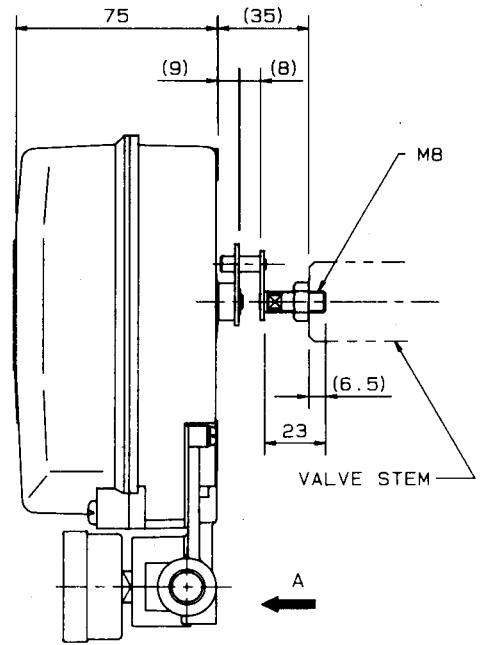
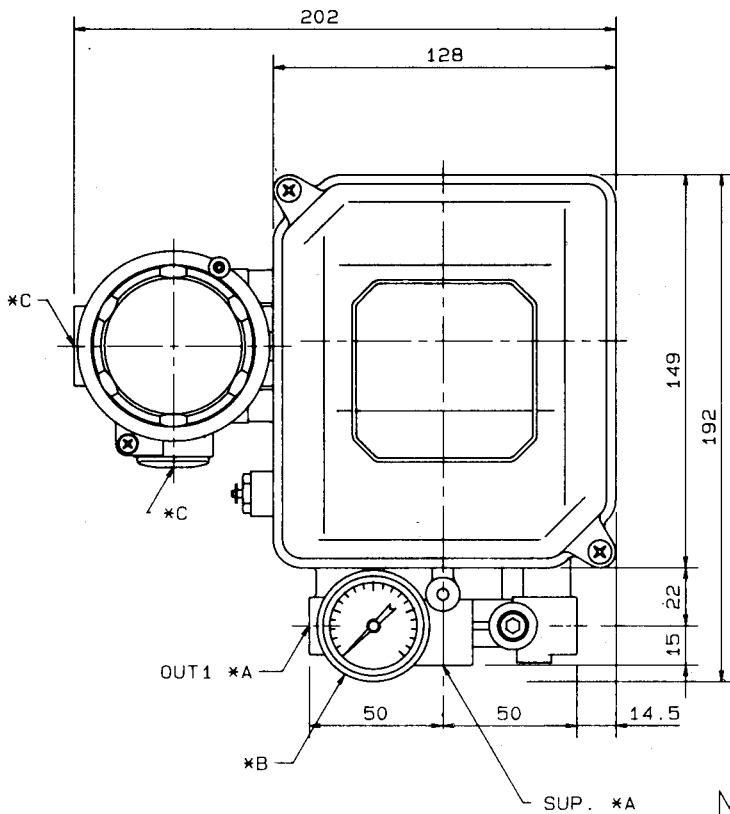

MODEL EPA8□4-L□□

*1	PROOF TYPE
<input type="checkbox"/> 0	WEATHER PROOF
<input type="checkbox"/> 1	ExmdIICT6
<input type="checkbox"/> 2	ExiaIICT6

*1 *2 *3

*2	GAUGE TYPE			
<input type="checkbox"/> 2	<input type="checkbox"/> 2kgf/cm ²	<input type="checkbox"/> 200kPa	<input type="checkbox"/> 2bar	<input type="checkbox"/> 30psi
<input type="checkbox"/> 4	<input type="checkbox"/> 4kgf/cm ²	<input type="checkbox"/> 400kPa	<input type="checkbox"/> 4bar	<input type="checkbox"/> 60psi
<input type="checkbox"/> 10	<input type="checkbox"/> 10kgf/cm ²	<input type="checkbox"/> 1000kPa	<input type="checkbox"/> 10bar	<input type="checkbox"/> 160psi

*3	SERVICE		
<input type="checkbox"/>	<input type="checkbox"/> WEATHER PROOF	<input type="checkbox"/> ExmdIICT6	<input type="checkbox"/> ExiaIICT6
<input type="checkbox"/>	-20~80°C <STANDARD>	-20~60°C	-20~60°C
<input type="checkbox"/> L	-50~60°C <LOW TEMP.>		-40~60°C
<input type="checkbox"/> H	0~100°C <HIGH TEMP.>		

		*A *B CONNECTION		
DESCRIPTION	UNIT	<input type="checkbox"/> kgf/cm ² kPa	<input type="checkbox"/> bar, psi kPa	<input type="checkbox"/> SPECIAL
*A AIR CONNECTION		Rc 1/4"	1/4"NPT	
*B GAUGE CONNECTION		Rc 1/8"	1/8"NPT	

Rc=PT
G=PF

*C	CONDUIT CONNECTION
<input type="checkbox"/>	G 1/2"
<input type="checkbox"/>	1/2"NPT

APPROX. WEIGHT: 2.3kg

A VIEW

NOTE

FOR SPRING RETURN ACTING ACTUATOR

DRAWING No.

E-EPAB04

REV

F

KOSO

ELECTRO-PNEUMATIC POSITIONER

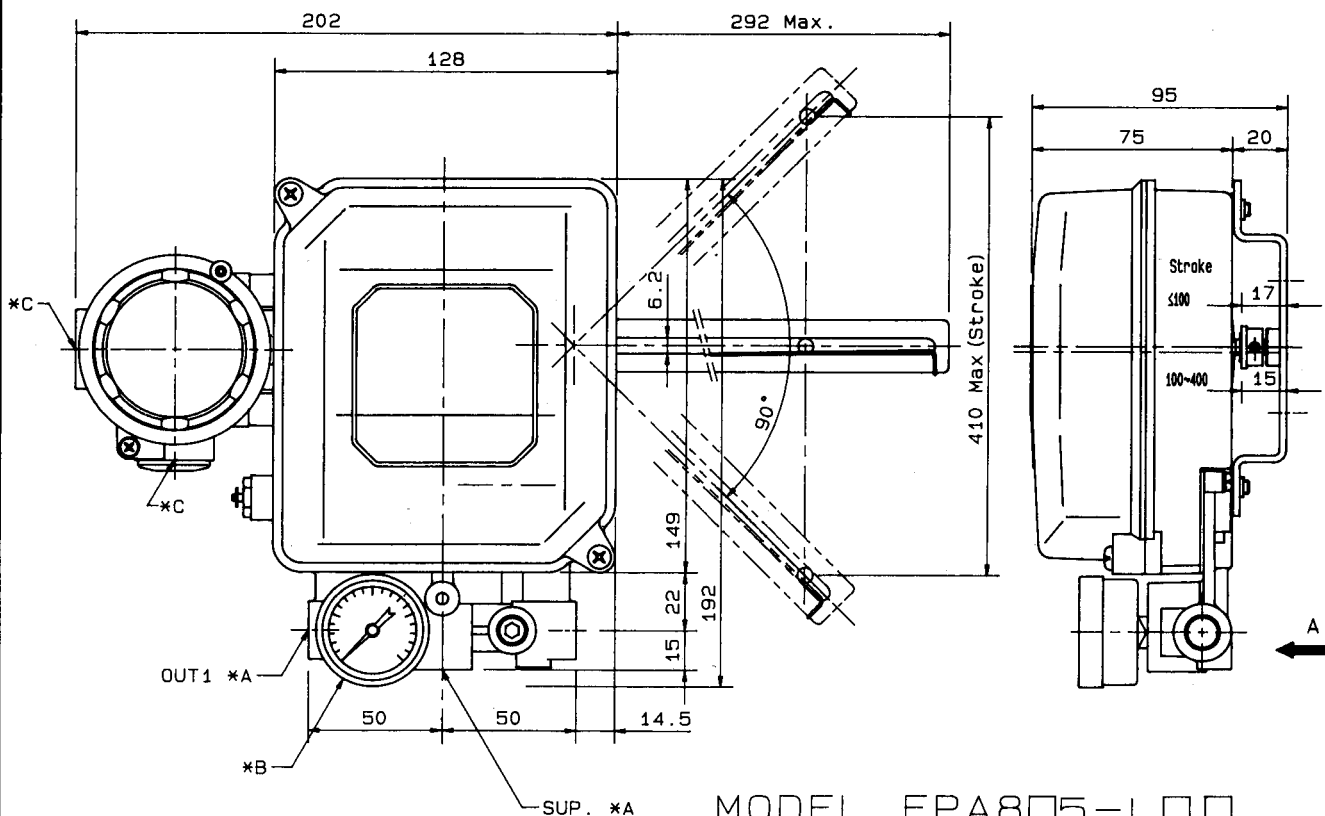

MODEL EPA8□5-L□□

*1	PROOF TYPE
<input type="checkbox"/> 0	WEATHER PROOF
<input type="checkbox"/> 1	ExmdIICT6
<input type="checkbox"/> 2	ExiaIICT6

*2	GAUGE TYPE			
<input type="checkbox"/> 2	<input type="checkbox"/> 2kgf/cm ²	<input type="checkbox"/> 200kPa	<input type="checkbox"/> 2bar	<input type="checkbox"/> 30psi
<input type="checkbox"/> 4	<input type="checkbox"/> 4kgf/cm ²	<input type="checkbox"/> 400kPa	<input type="checkbox"/> 4bar	<input type="checkbox"/> 60psi
<input type="checkbox"/> 10	<input type="checkbox"/> 10kgf/cm ²	<input type="checkbox"/> 1000kPa	<input type="checkbox"/> 10bar	<input type="checkbox"/> 160psi

*3	SERVICE		
<input type="checkbox"/>	<input type="checkbox"/> WEATHER PROOF	<input type="checkbox"/> ExmdIICT6	<input type="checkbox"/> ExiaIICT6
<input type="checkbox"/>	-20~80°C <STANDARD>	-20~60°C	-20~60°C
<input type="checkbox"/> L	-50~60°C <LOW TEMP.>		-40~60°C
<input type="checkbox"/> H	0~100°C <HIGH TEMP.>		

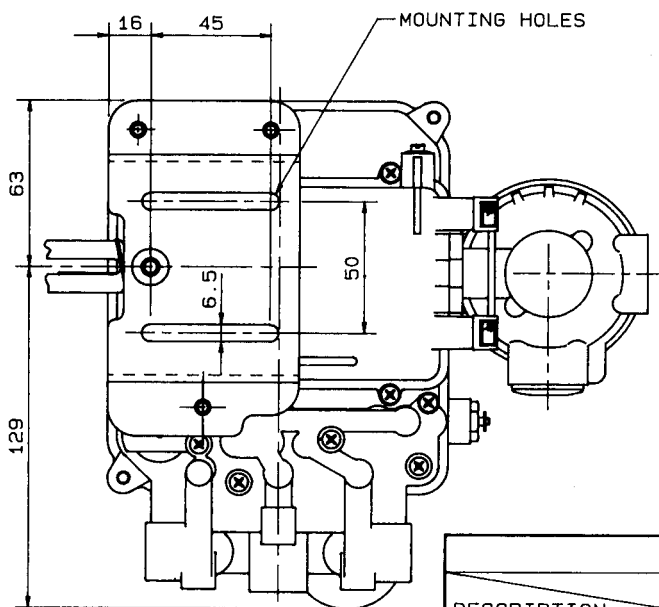

A VIEW

		*A *B CONNECTION		
DESCRIPTION	UNIT	<input type="checkbox"/> kgf/cm ² kPa	<input type="checkbox"/> bar, psi kPa	<input type="checkbox"/> SPECIAL
*A AIR CONNECTION		Rc 1/4"	1/4"NPT	
*B GAUGE CONNECTION		Rc 1/8"	1/8"NPT	

Rc=PT
G=PF

*C	CONDUIT CONNECTION
<input type="checkbox"/>	G 1/2"
<input type="checkbox"/>	1/2"NPT

APPROX. WEIGHT: 2.5kg

NOTE:

FOR SPRING RETURN ACTING ACTUATOR

DRAWING No.

E-EPAB05

REV

D

KOSO

ELECTRO-PNEUMATIC POSITIONER

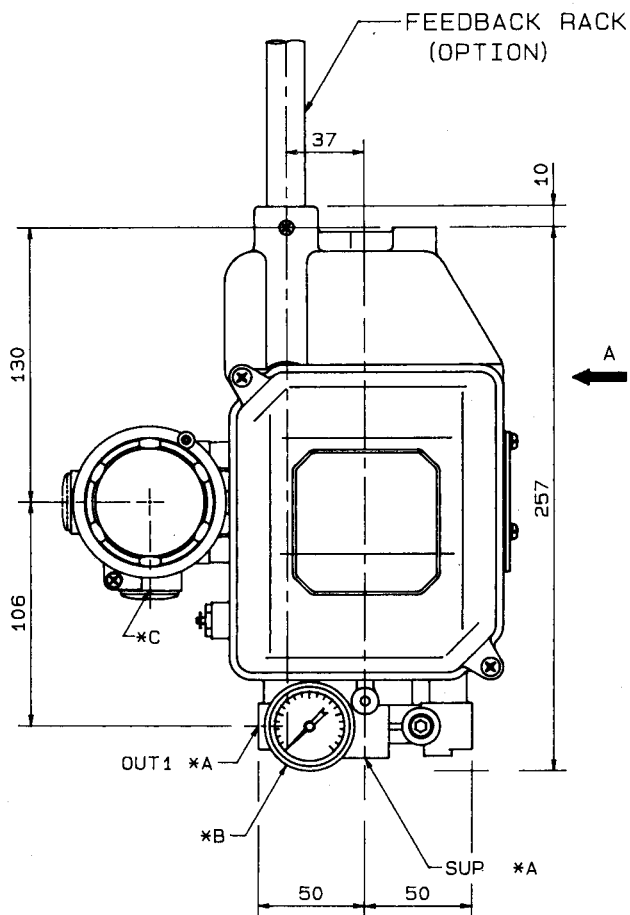
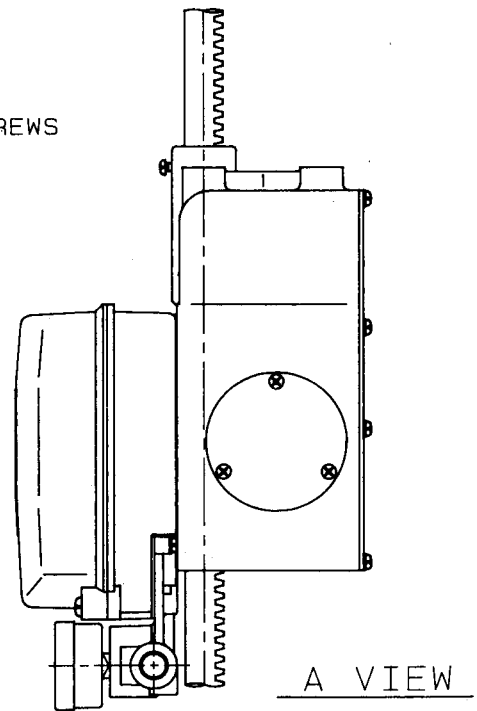
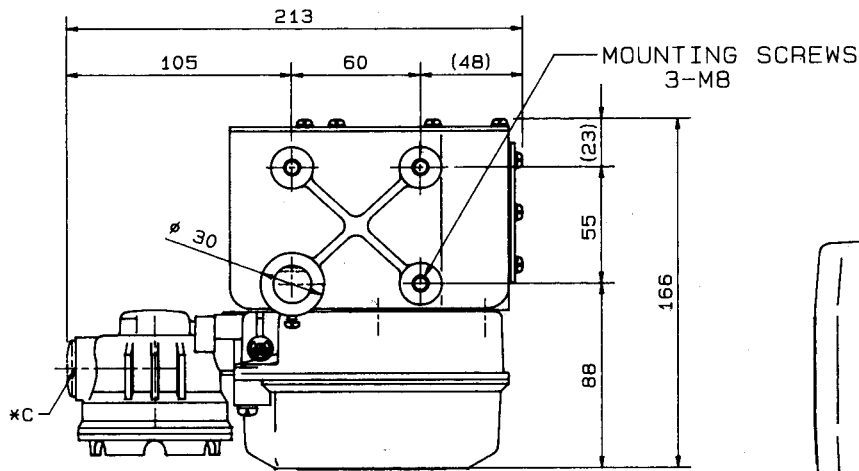

MODEL EPA8□8-L□□

*1	PROOF TYPE	*1	*2	*3
□0	WEATHER PROOF			
□1	ExmdIICT6			
□2	ExiaIICT6			

*2	GAUGE TYPE				
□2	□2kgf/cm ²	□200kPa	□2bar	□30psi	
□4	□4kgf/cm ²	□400kPa	□4bar	□60psi	
□10	□10kgf/cm ²	□1000kPa	□10bar	□160psi	

*3	SERVICE		
	□ WEATHER PROOF	□ ExmdIICT6	□ ExiaIICT6
□	-20~80°C <STANDARD>	-20~60°C	-20~60°C
□L	-50~60°C <LOW TEMP.>		-40~60°C
□H	0~100°C <HIGH TEMP.>		

*C	CONDUIT CONNECTION
□	G 1/2"
□	1/2"NPT

		*A *B CONNECTION		
DESCRIPTION	UNIT	□ kgf/cm ² kPa	□ bar, psi kPa	□ SPECIAL
*A AIR CONNECTION		Rc 1/4"	1/4"NPT	
*B GAUGE CONNECTION		Rc 1/8"	1/8"NPT	

Rc=PT
G=PF

APPROX. WEIGHT: 3.9kg

NOTE:

FOR SINGLE RETURN ACTING ACTUATOR

DRAWING No.

E-EPA808

REV

C

KOSO

ELECTRO-PNEUMATIC POSITIONER

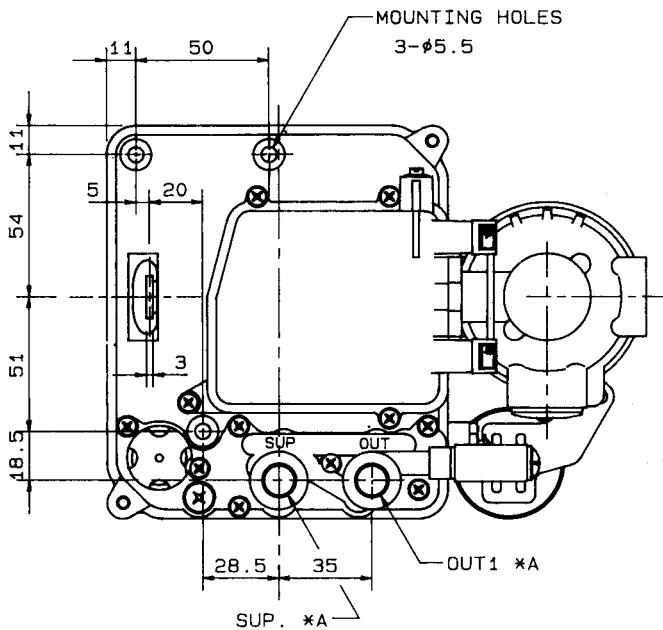
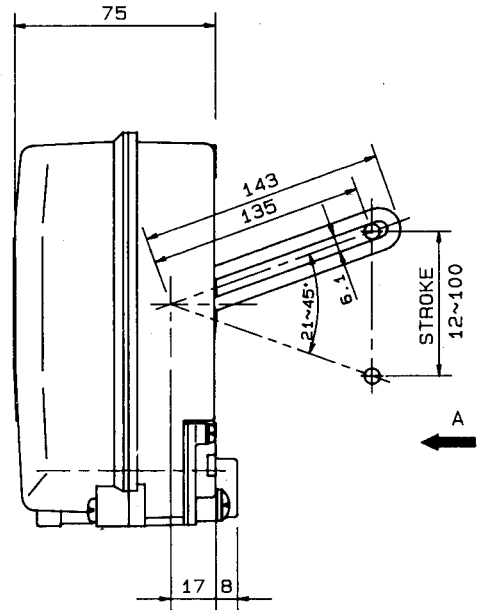
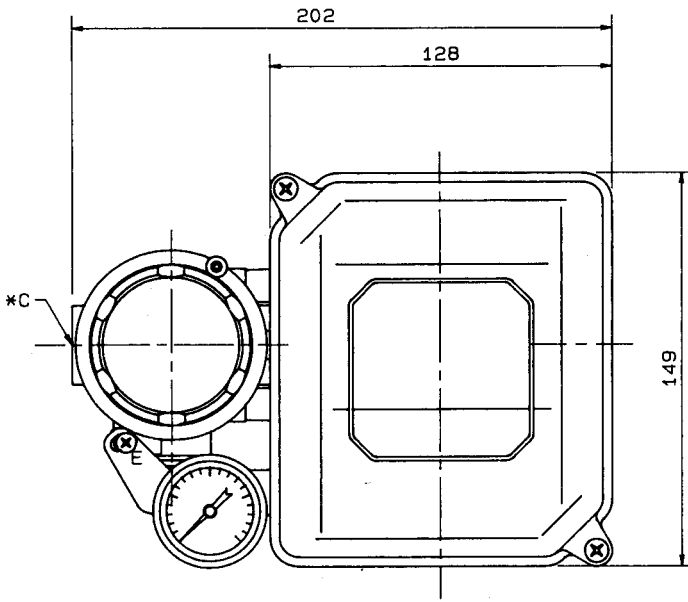

MODEL EPB8□1-L□□

*1	PROOF TYPE	*1	*2	*3
□0	WEATHER PROOF			
□1	ExmdIICT6			
■2	ExiaIICT6			

*2	GAUGE TYPE			
□2	□2kgf/cm ²	□200kPa	□2bar	□30psi
■4	□4kgf/cm ²	□400kPa	□4bar	□60psi
□10	□10kgf/cm ²	□1000kPa	□10bar	□160psi

*3	SERVICE		
	□ WEATHER PROOF	□ ExmdIICT6	□ ExiaIICT6
■	-20~80°C <STANDARD>	-20~60°C	-20~60°C
□L	-50~60°C <LOW TEMP.>		-40~60°C
□H	0~100°C <HIGH TEMP.>		

A VIEW

	*A	*B	CONNECTION	
DESCRIPTION	UNIT	□ kgf/cm ² kPa	□ bar, psi kPa	□ SPECIAL
*A	AIR CONNECTION	Rc 1/4"	1/4"NPT	
*B	GAUGE CONNECTION	Rc 1/8"	1/8"NPT	

Rc=PT
G=PF

*C	CONDUIT CONNECTION
□	G 1/2"
□	1/2"NPT

APPROX. WEIGHT: 2.2kg

NOTE:

FOR SPRING RETURN ACTING ACTUATOR

DRAWING No.

E-EPB801

REV

E

KOSO

ELECTRO-PNEUMATIC POSITIONER

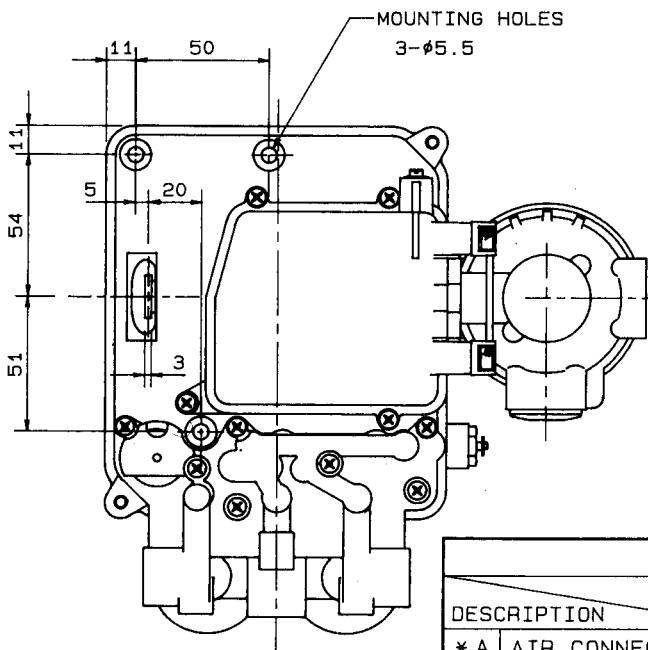
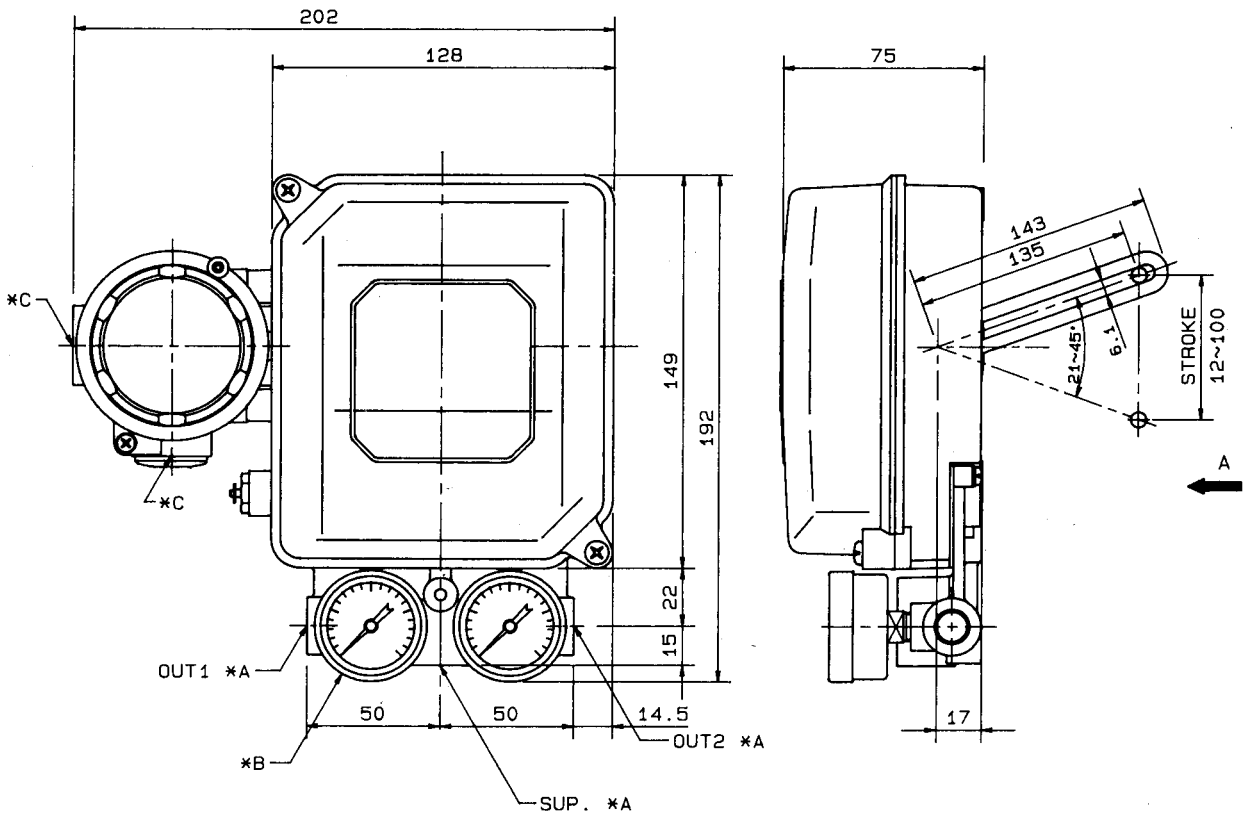

MODEL EPC8□1-L□□

*1	PROOF TYPE	*1	*2	*3
□0	WEATHER PROOF			
□1	ExmdIICT6			
■2	ExiaIICT6			

*2	GAUGE TYPE			
■10	□10kgf/cm ²	□1000kPa	□10bar	□160psi

*3	SERVICE		
	□ WEATHER PROOF	□ ExmdIICT6	□ ExiaIICT6
■	-20~80°C <STANDARD>	-20~60°C	-20~60°C
□L	-50~50°C <LOW TEMP.>		-40~60°C
□H	0~100°C <HIGH TEMP.>		

		*A *B CONNECTION		
DESCRIPTION	UNIT	□ kgf/cm ² kPa	□ bar, psi kPa	□ SPECIAL
*A AIR CONNECTION		Rc 1/4"	1/4"NPT	
*B GAUGE CONNECTION		Rc 1/8"	1/8"NPT	

Rc=PT
G=PF

*C	CONDUIT CONNECTION
□	G 1/2"
□	1/2"NPT

APPROX. WEIGHT: 2.4kg

NOTE:

FOR DOUBLE ACTING ACTUATOR

DRAWING No.

E-EPC801

REV

E

KOSO

ELECTRO-PNEUMATIC POSITIONER

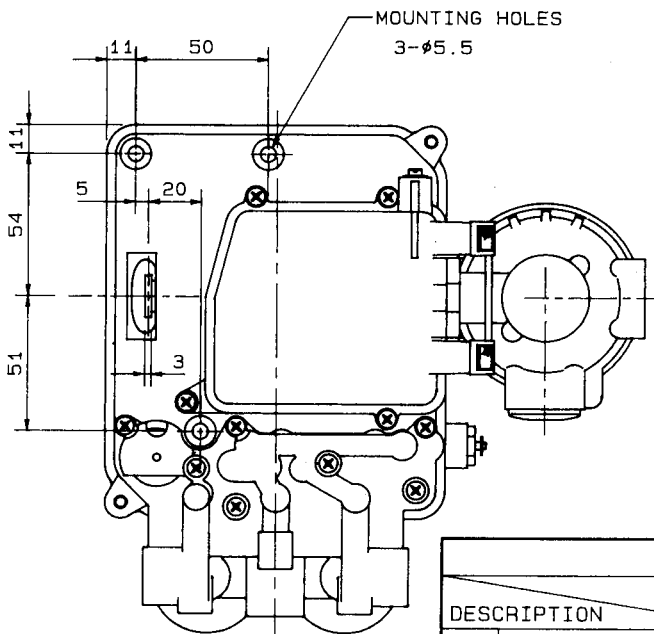
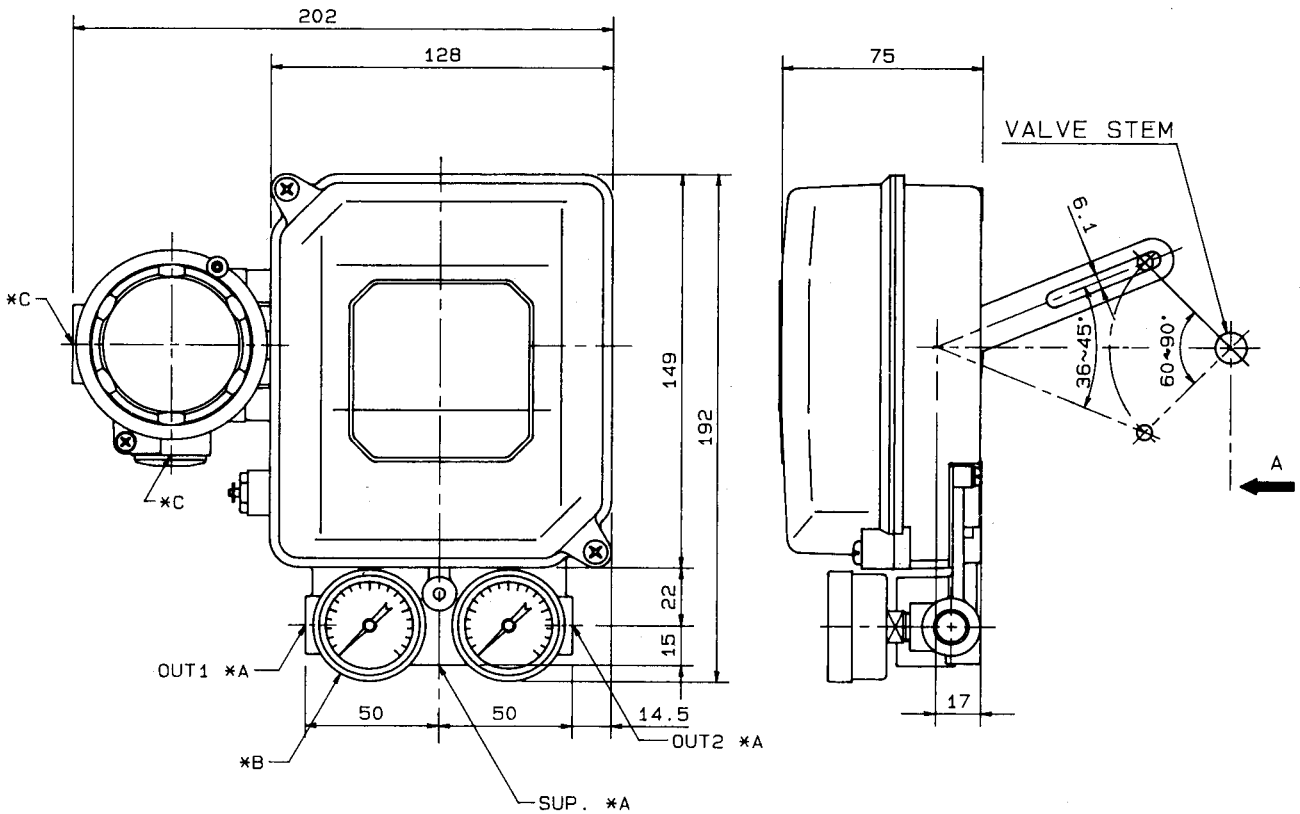

A VIEW

MODEL EPC8□2-L□□

*1	PROOF TYPE	*1	*2	*3
□0	WEATHER PROOF			
□1	ExmdIICT6			
□2	ExiaIICT6			

*2	GAUGE TYPE				
□10	□10kgf/cm ²	□1000kPa	□10bar	□160psi	

*3	SERVICE		
□	□ WEATHER PROOF	□ ExmdIICT6	□ ExiaIICT6
□	-20~80°C <STANDARD>	-20~60°C	-20~60°C
□L	-50~60°C <LOW TEMP.>		-40~60°C
□H	0~100°C <HIGH TEMP.>		

		*A *B CONNECTION		
DESCRIPTION	UNIT	□ kgf/cm ² kPa	□ bar, psi kPa	□ SPECIAL
*A AIR CONNECTION		Rc 1/4"	1/4"NPT	
*B GAUGE CONNECTION		Rc 1/8"	1/8"NPT	

Rc=PT
G=PF

*C	CONDUIT CONNECTION
□	G 1/2"
□	1/2"NPT

APPROX. WEIGHT: 2.4kg

NOTE:

FOR DOUBLE ACTING ACTUATOR

DRAWING No.

E-EPC802

REV

E

KOSO

ELECTRO-PNEUMATIC POSITIONER

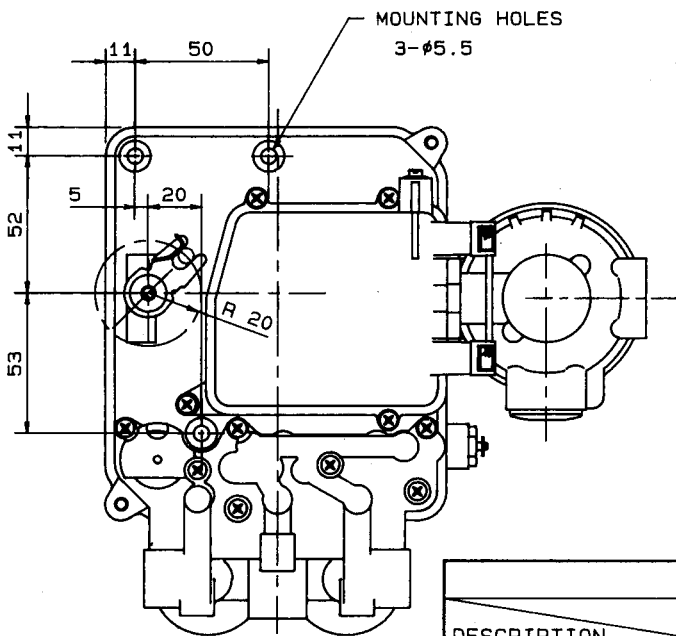
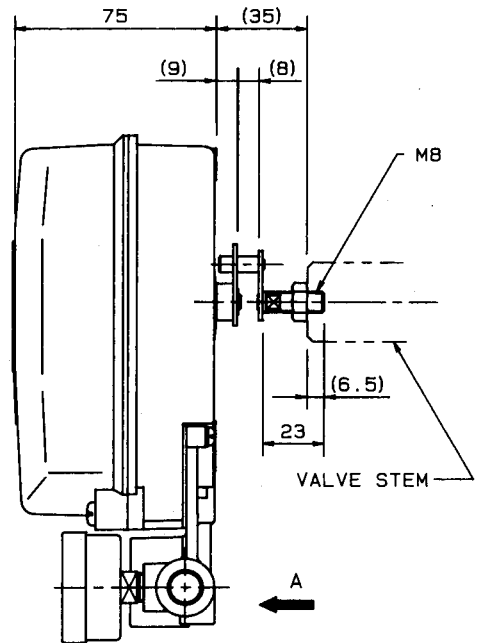
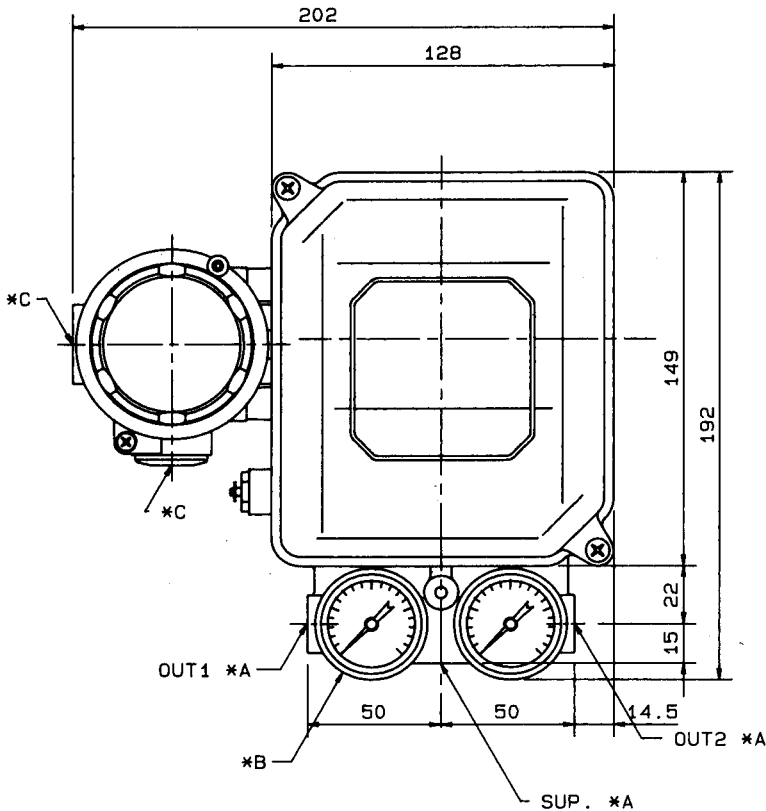

MODEL EPC8□4-L□□

*1	PROOF TYPE	*1	*2	*3
□0	WEATHER PROOF			
□1	ExmdIICT6			
□2	ExiaIICT6			
*2	GAUGE TYPE			
□10	□10kgf/cm ²	□1000kPa	□10bar	□150psi
*3	SERVICE			
	□ WEATHER PROOF	□ ExmdIICT6	□ ExiaIICT6	
□	-20~80°C <STANDARD>	-20~60°C	-20~60°C	
□L	-50~60°C <LOW TEMP.>		-40~60°C	
□H	0~100°C <HIGH TEMP.>			

		*A	*B	CONNECTION	
DESCRIPTION	UNIT	kgf/cm ²		bar, psi	
		□	□	□	□
*A	AIR CONNECTION	Rc 1/4"	1/4"NPT		
*B	GAUGE CONNECTION	Rc 1/8"	1/8"NPT		

Rc=PT
G=PF

*C	CONDUIT CONNECTION
□	G 1/2"
□	1/2"NPT

APPROX. WEIGHT: 2.4kg

A VIEW

NOTE:

FOR DOUBLE ACTING ACTUATOR

DRAWING No.

E-EPC804

REV

F

KOSO

ELECTRO-PNEUMATIC POSITIONER

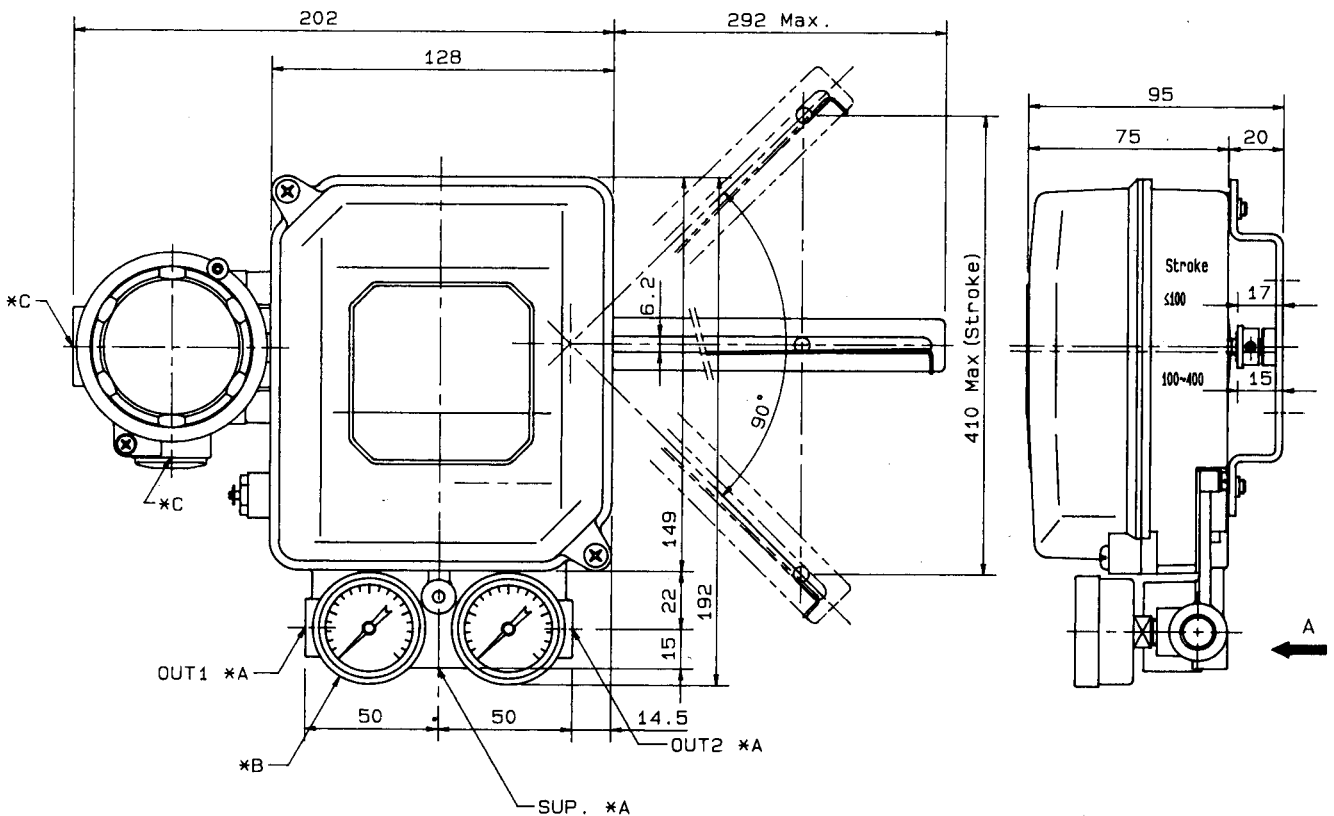

MODEL EPC8□5-L□□

*1	PROOF TYPE	*1	*2	*3
□0	WEATHER PROOF			
□1	ExmdIICT6			
□2	ExiaIICT6			

*2	GAUGE TYPE				
□10	□10kgf/cm ²	□1000kPa	□10bar	□160psi	

*3	SERVICE		
□	□ WEATHER PROOF	□ ExmdIICT6	□ ExiaIICT6
□	-20~80°C <STANDARD>	-20~60°C	-20~60°C
□L	-50~60°C <LOW TEMP.>		-40~60°C
□H	0~100°C <HIGH TEMP.>		

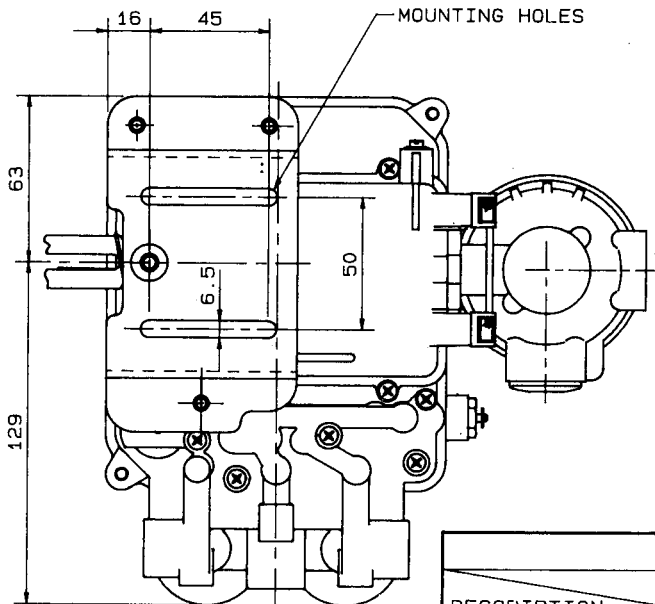

A VIEW

		*A	*B	CONNECTION		
DESCRIPTION	UNIT	□ kgf/cm ² kPa	□ bar, psi kPa	□ SPECIAL		
*A	AIR CONNECTION	Rc 1/4"	1/4"NPT			
*B	GAUGE CONNECTION	Rc 1/8"	1/8"NPT			

Rc=PT
G=PF

*C	CONDUIT CONNECTION
□	G 1/2"
□	1/2"NPT

APPROX. WEIGHT: 2.6kg

NOTE:

FOR DOUBLE ACTING ACTUATOR

DRAWING No.

E-EPC805

REV

D

KOSO

ELECTRO-PNEUMATIC POSITIONER

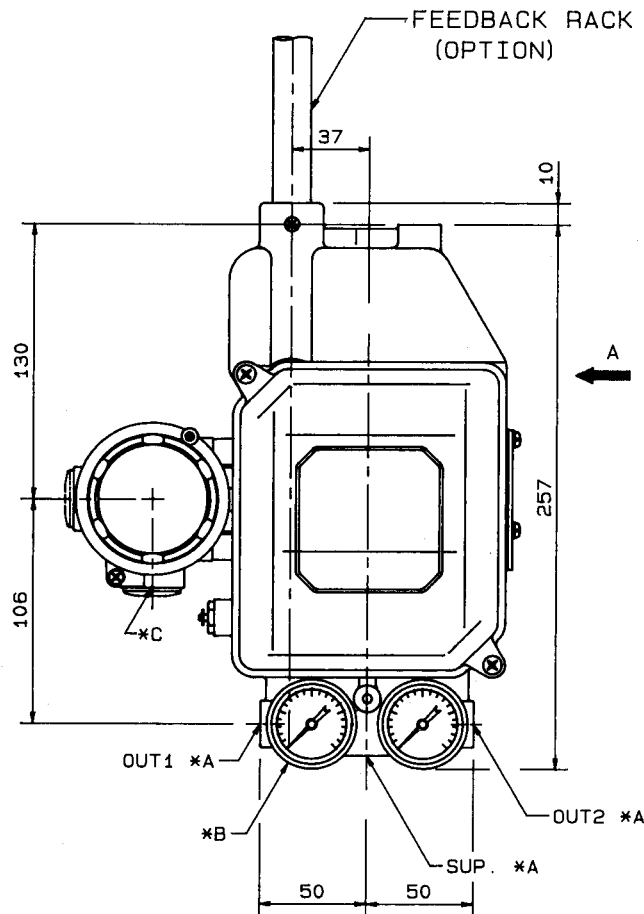
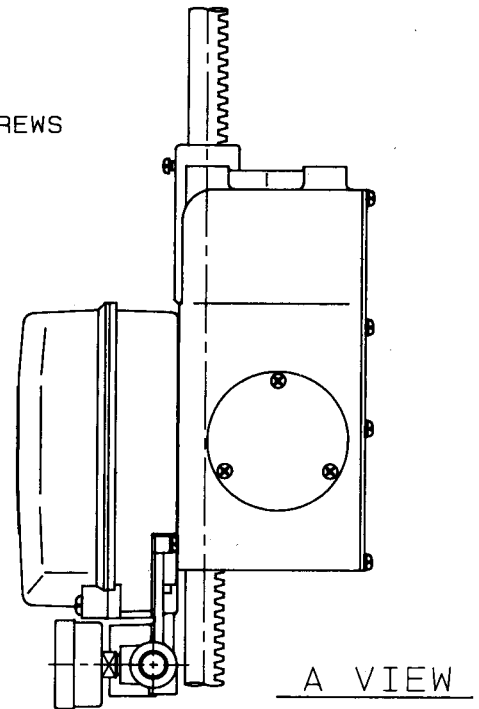
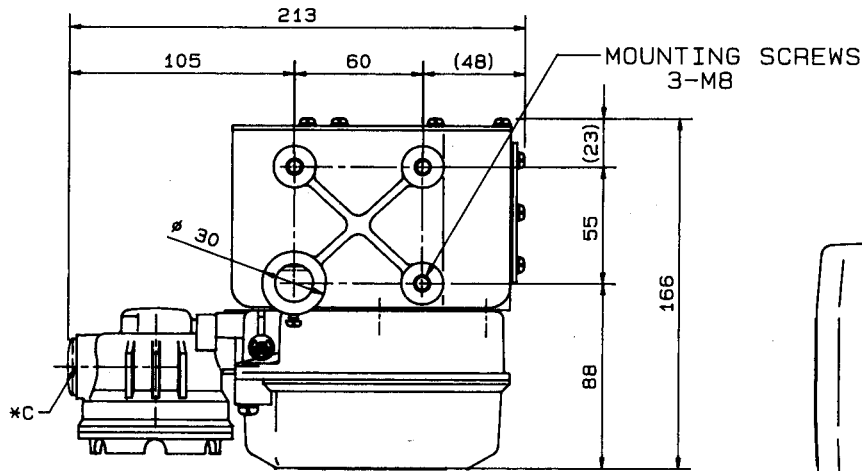

MODEL EPC8□8-L□□

*1 PROOF TYPE

<input type="checkbox"/> 0	WEATHER PROOF
<input type="checkbox"/> 1	Exmd IICT6
<input type="checkbox"/> 2	Exia IICT6

*2 GAUGE TYPE

<input type="checkbox"/> 10	<input type="checkbox"/> 10kgf/cm ²	<input type="checkbox"/> 1000kPa	<input type="checkbox"/> 10bar	<input type="checkbox"/> 160psi
-----------------------------	--	----------------------------------	--------------------------------	---------------------------------

*3 SERVICE

<input type="checkbox"/>	WEATHER PROOF	<input type="checkbox"/> Exmd IICT6	<input type="checkbox"/> Exia IICT6
<input type="checkbox"/>	-20~80°C <STANDARD>	-20~60°C	-20~60°C
<input type="checkbox"/> L	-50~60°C <LOW TEMP.>		-40~60°C
<input type="checkbox"/> H	0~100°C <HIGH TEMP.>		

*C CONDUIT CONNECTION

<input type="checkbox"/>	G 1/2"
<input type="checkbox"/>	1/2"NPT

*A *B CONNECTION

DESCRIPTION	UNIT	CONNECTION		<input type="checkbox"/> SPECIAL
		<input type="checkbox"/> kgf/cm ² kPa	<input type="checkbox"/> bar, psi kPa	
*A AIR CONNECTION	Rc 1/4"	1/4"NPT		
*B GAUGE CONNECTION	Rc 1/8"	1/8"NPT		

Rc=PT
G=PF

APPROX. WEIGHT: 4.0kg

NOTE:

FOR DOUBLE ACTING ACTUATOR

DRAWING No.

E-EPC808

REV

C

KOSO